



AIR CONDITIONING



REFRIGERATION



HEATING



standard

CONDENSATE REMOVAL PUMP



Operated by an air conditioning cooling signal, the Standard peristaltic sets the standard for reliability. The remote install options means minimum future maintenance disruption.



6.5L/h max. flow



12m max. head (flow rate 6.5L/h)

KEY FEATURES

- AC cooling signal operated
- Remote install possible
- Pumps contaminated water
- Can run dry

SUITABILITY

- Up to 8.5kW / 29,000Btu/h
- High wall split systems; Ducted units; Floor standing & Chassis units

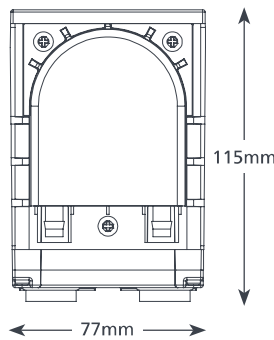
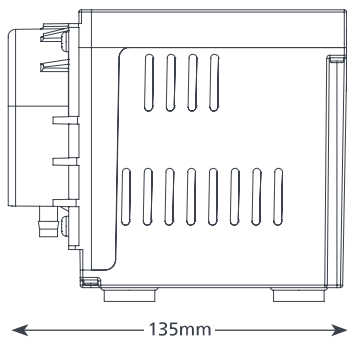

STANDARD SPECIFICATIONS

Max. flow	6.5L/h @ 12m head
Max. head	12m
Max. suction lift	3m
Sound level@1m	47dB(A)
Power supply	230 VAC, 0.2A, 50-60Hz
Rated Class	Continuously I appliance
Max. unit output	8.5kW / 29,000Btu/h
Max. water temp	40°C / 104°F
Inlet/outlet	6mm ID
IP Protection	IP21
Safety switch	n/a
Thermal protection	✓
Fully potted	n/a
Self priming	✓

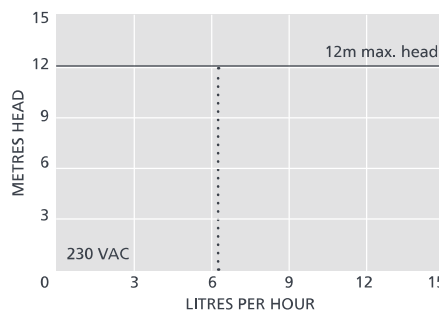

SUGGESTED XTRA ACCESSORIES

Description	Part No.
Peri Spare Tube Kit	FP1282
1 Amp Fuse	FP2620
Tube To Soil Stack Adaptor	FP2038

Xtra For more installation accessories take a look at our Aspen Xtra range

STANDARD OPTIONS

Standard	FP2081/2
----------	----------

IN THE BOX

- Standard pump
- 2m Plug & play power cable
- Wall mounted bracket
- Fixing kit
- Install manual

- 📖 Download manual at aspenpumps.com
- ▶ View install video at aspenpumps.com

Information correct at time of going to press.

